

LC3722D Three-Phase Step Drive

User Manual

Contents

Chapter I Product Introduction	1
1.1 Product Introduction	1
1.2 Product specifications	1
1.3 Mounting dimensions	1
Chapter II Wiring and Setting	2
2.1 Description of terminal function.....	2
2.1.1 Power supply terminal	2
2.1.2 Control signal connection terminal	2
2.2 Wiring instructions.....	2
2.2.1 Input signal wiring diagram (5-24V voltage supported).....	2
2.2.2 Output signal wiring diagram	3
2.2.3 Signal control sequence diagram	3
2.3 Dial function description	4
2.3.1 Current setting	4
2.3.2 Subdivision setting.....	4
2.2.3 Other settings	4
Chapter III Troubleshooting	5
4.1 Common faults and troubleshooting.....	5

Chapter I Product Introduction

1.1 Product Introduction

LC3722D is a new generation digital two-phase step drive developed based on the 32-bit DSP technology. The control signal plug is modified based on those for old models, so the operation is easier. A dialing switch allowing 1MHz and 200Hz pulse input mode switching is added to the drive, effectively solving the interference problem happened sometimes and making the product application more popular. This drive combines more advanced algorithms, greatly reducing the noise caused by the motor during operation and making the motor run more stably and reliably.

1.2 Product specifications

- Voltage input range: AC110V~280V
- Max. peak current: 7.0A
- Subdivision range: 400~60000ppr
- Pulse form: pulse + direction (dual-pulse not supported)
- Pulse response frequency: 0~1MHz
- When the pulse stops for 1.5s, the coil current will be automatically reduced to half of the set value
- Provided with overvoltage, overcurrent and motor phase loss protection functions, etc.

1.3 Mounting dimensions

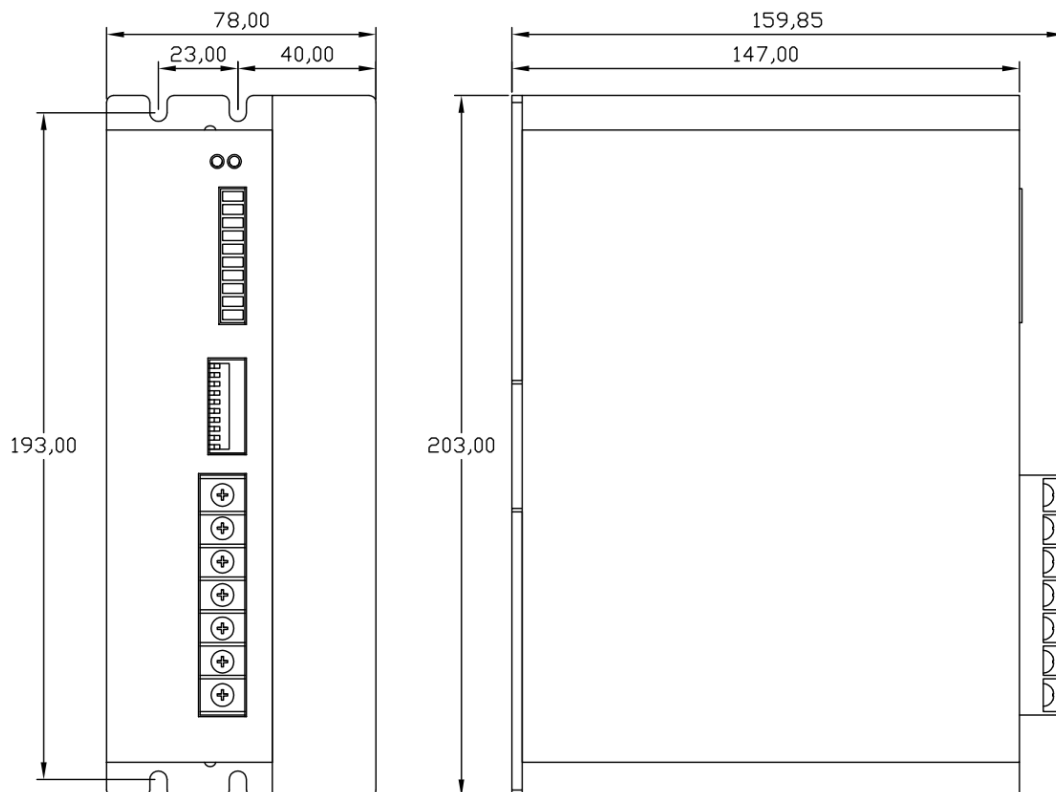

Chapter II Wiring and Setting

2.1 Description of terminal function

2.1.1 Power supply terminal

Terminal No.	Symbol	Description
1	NC	Not connected
2	U	Three-phase step motor winding
3	V	
4	W	
5	PE	Earth
6	AC	AC power input terminal AC110V~280V
7	AC	

2.1.2 Control signal connection terminal

Terminal No.	Symbol	Description
1	PLS+	Pulse signal input terminal (5V-24V)
2	PLS-	
3	DIR+	Direction signal input terminal (5V-24V)
4	DIR-	
5	ENA+	Release signal input terminal (5V-24V)
6	ENA-	
7	ALM+	Alarm signal output terminal Normally closed output
8	ALM-	
9	RDY+	Output terminal of ready signal Normally closed output
10	RDY-	

2.2 Wiring instructions

2.2.1 Input signal wiring diagram (5-24V voltage supported)

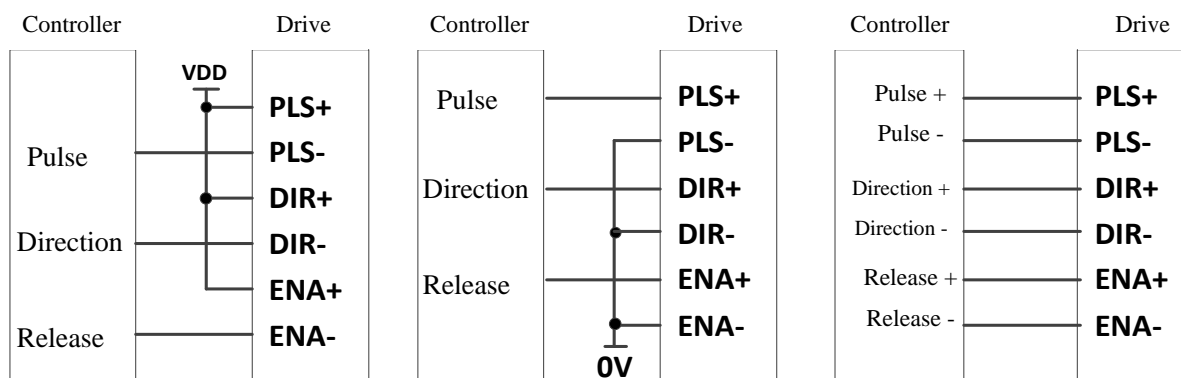

Common anode connection method

Common cathode connection method

Differential signal connection method

2.2.2 Output signal wiring diagram

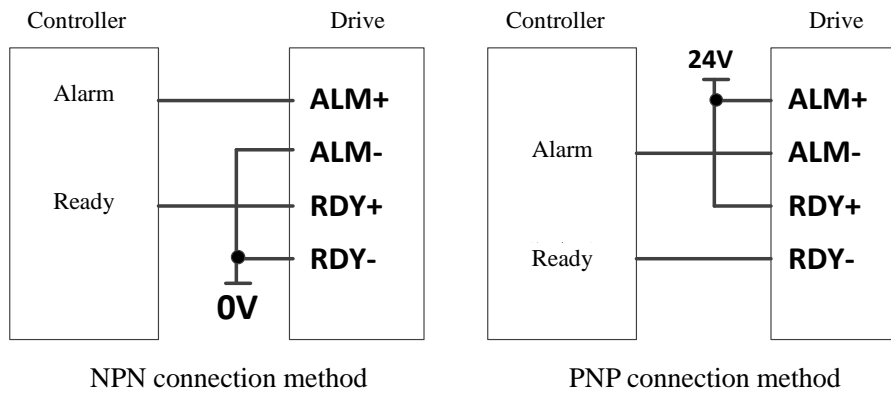

2.2.3 Signal control sequence diagram

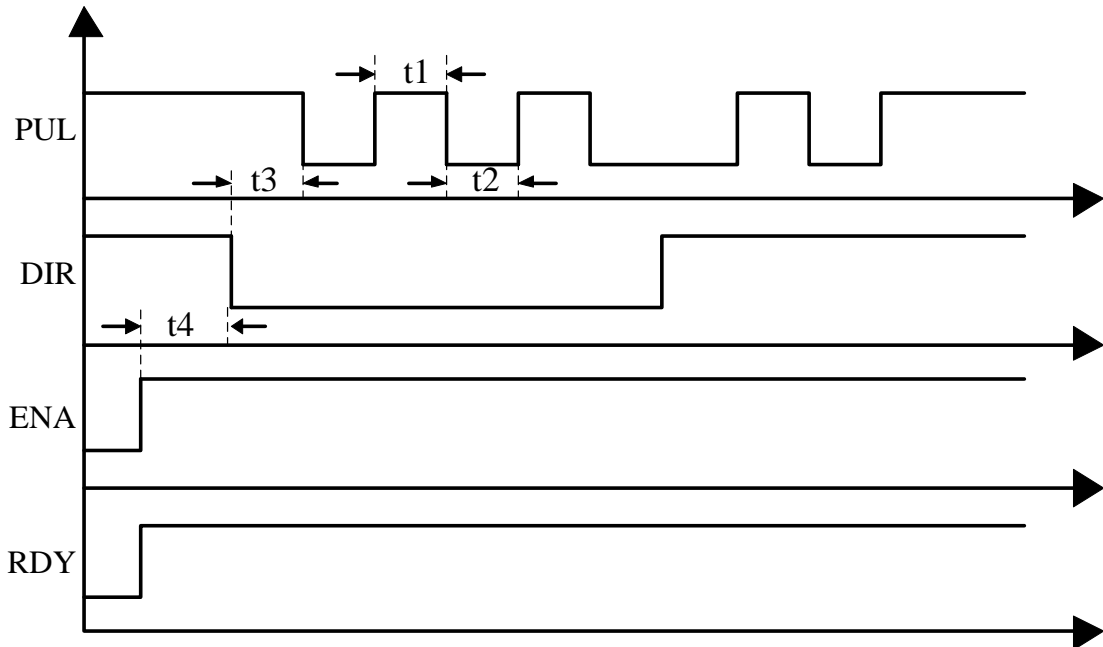

Note: When SW10 is OFF, t_1 and t_2 should be higher than 5 μ s; When SW10 is ON, t_1 and t_2 should be higher than 2ns.

t_3 and t_4 should be higher than 1ms.

2.3 Dial function description

2.3.1 Current setting

Current	SW1	SW2	SW3	SW4
1.2	OFF	OFF	OFF	OFF
1.5	OFF	OFF	OFF	ON
2.0	OFF	OFF	ON	OFF
2.3	OFF	OFF	ON	ON
2.5	OFF	ON	OFF	OFF
3.0	OFF	ON	OFF	ON
3.2	OFF	ON	ON	OFF
3.6	OFF	ON	ON	ON
4.0	ON	OFF	OFF	OFF
4.5	ON	OFF	OFF	ON
5.0	ON	OFF	ON	OFF
5.3	ON	OFF	ON	ON
5.8	ON	ON	OFF	OFF
6.2	ON	ON	OFF	ON
6.5	ON	ON	ON	OFF
7.0	ON	ON	ON	ON

2.3.2 Subdivision setting

Subdivision	SW5	SW6	SW7	SW8
400	ON	ON	ON	ON
500	ON	ON	ON	OFF
600	ON	ON	OFF	ON
800	ON	ON	OFF	OFF
1000	ON	OFF	ON	ON
1200	ON	OFF	ON	OFF
2000	ON	OFF	OFF	ON
3000	ON	OFF	OFF	OFF
4000	OFF	ON	ON	ON
5000	OFF	ON	ON	OFF
6000	OFF	ON	OFF	ON
10000	OFF	ON	OFF	OFF
8000	OFF	OFF	ON	ON
20000	OFF	OFF	ON	OFF
30000	OFF	OFF	OFF	ON
60000	OFF	OFF	OFF	OFF

2.2.3 Other settings

SW9: Filtering time, OFF=3ms, ON=25ms

Internal acceleration / deceleration time of drive.

SW10: Pulse frequency limitation, OFF=200KHz, ON=1MHz

When it is set to OFF, the maximum input pulse frequency is limited to 200KHz to prevent inaccurate motor positioning caused by external interference signals.

Chapter III Troubleshooting

4.1 Common faults and troubleshooting

Fault	Problem description	Fault handling
Motor not running	Incorrect pulse signal line connection	Check the pulse and direction signal lines for being connected reversely
	Pulse port damaged	Sending it back for maintenance
	Voltage input to release signal line	Check the release signal for being normal
	Drive alarm	Handle according to the corresponding alarm information
Motor running error	Loose locking at the connection part between the motor axis and machine	Check the coupling or gear for being fixed
	Motor stalled due to heavy load	Reduce the load or use a bigger motor
	Too low set current, causing step-out	Increase the current
	Step-out due to interference signal input	Connect the ground wire and set SW10 to OFF
	Step-out due to too fast acceleration / deceleration	Slow down the acceleration and deceleration time of the program
	Drive subdivision setting error	Reset subdivision
The red light flashes once every 3 seconds	Overcurrent alarm	<ol style="list-style-type: none"> 1. Motor power line short circuit or motor fault; 2. Too high set current, dial the current to a low level; 3. Internal fault of drive, sent it back to the factory for maintenance.
The red light flashes twice every 3 seconds	Overvoltage alarm	<ol style="list-style-type: none"> 1. Check for too high power supply voltage, reduce the voltage or replace the power supply if necessary; 2. Internal fault of drive, sent it back to the factory for maintenance.
The red light flashes thrice every 3 seconds	Internal voltage error	<ol style="list-style-type: none"> 1. Internal fault of drive, sent it back to the factory for maintenance.
The red light flashes 4 times every 3 seconds	No motor alarm	<ol style="list-style-type: none"> 1. Check the motor line for being disconnected or connected incorrectly; 2. Check the fixed terminals of the motor line in the rear cover of the motor for being in good contact; 3. Internal fault of drive, sent it back to the factory for maintenance.